

Smith Meter® In-Line Strainers are necessary to provide protection for metering systems against dirt and other foreign material. Strainers are available in straight-thru (2" - 8") and angle type (4" and 6").

Standard Features

- Removable basket for easy cleaning.
- Meets design requirements of ASME B31.3.
- NACE MR-01-75 compliance for products with hydrogen sulfide concentrations.
- 0.50" NPT differential pressure taps on the nozzles.
- 1.50" NPT Cover vent connection to mount Air Release Kit for static air elimination.
- ASME B16.5 Raised Face Flange standard.
- Horizontal or vertical operation.
- Basket Seal.

Optional Features

- Air Release Kits.
- Basket Differential Pressure Gauge Kit with isolation valves to monitor basket cleanliness.
- ΔP Gauge Reed Type Switch Kit, adjustable from 0–30 psi (0–207 kPa) for remote indication.

Note: For other strainers/options, consult Specification Bulletin No. SS03038.

Operating Specifications

Maximum Strainer Working Pressure

Flange Class	Working Pressure ¹ psi (kPa)
150	285 (1,965)
300	740 (5,102)

Basket Burst Pressure

50 psi differential.

Temperature Range

Seal Material	Range
Garlock	-20°F to 400°F (-29°C to 204°C)



Model S4-1-ST Strainer

	Opening Size Inches (mm)	Percent Open Area Through Inner and Outer Baskets
Permanent Liner		
40 (Std.)	0.015 (0.38)	25.9%
10	0.075 (1.91)	40.5%
20	0.036 (0.91)	37.3%
60	0.0082 (0.21)	24.2%
80	0.007 (0.18)	22.6%
No Liner		
Perforated Plate	0.125 (3.17)	40.0%

(Screens shown actual size.)

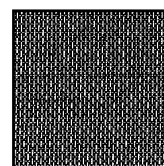

40 Mesh

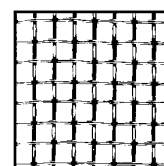

10 Mesh

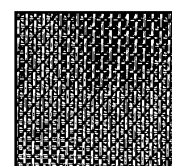

20 Mesh



60 Mesh

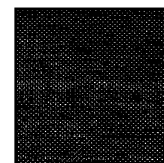

80 Mesh

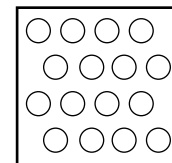

Perforated Plate

¹ Maximum working pressures are for temperatures of -20°F to 100°F (-28°C to 38°C). Operating temperatures above 100°F (38°C) affect allowable working pressures. Consult factory for allowable working pressures at required operating temperature.

Pressure Drop with 40 Mesh Liner

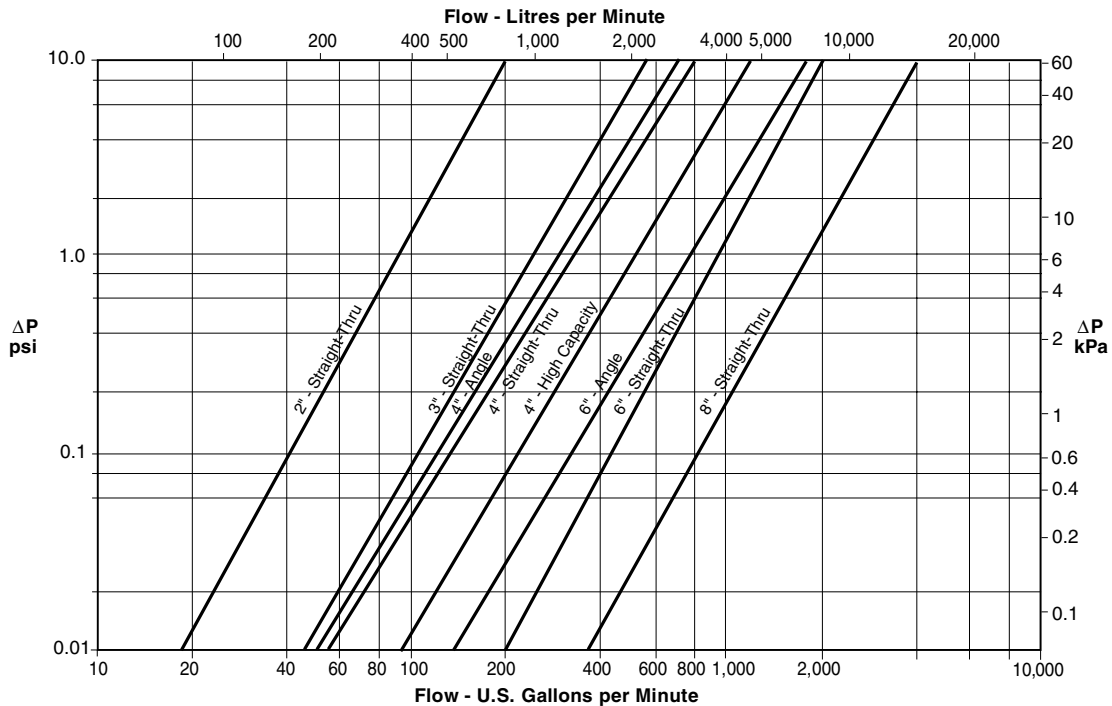

To approximate pressure drop for strainers with other than 40 mesh baskets, multiply chart reading by the appropriate factor.

Mesh	Factor
Perforated Plate	.65
10	.75
20	.85
60	1.11
80	1.25

Materials of Construction

Housing:	Carbon Steel
Flanges:	Carbon Steel
Basket/Liner:	304 Stainless Steel
Cover and Basket Seals:	Non-Asbestos Gasket

Body Style

Standard		High Capacity	
Strainer Size	Body Diameter	Strainer Size	Body Diameter
2"	4"	4"	10" (150 ANSI Class Only)
3"	6"		
4"	6"		
6"	10"		
8"	12"		

Maximum Working Pressure of Air Release Kits

Kit	Working Pressure ² psi (kPa)	Seals	Materials of Construction
RB-Type	285 psi @ 100°F (1,965 kPa @ 38°C)	Buna-N, Viton, LSB	Housing: Carbon Steel; Float: Stainless Steel; Internal Parts: Aluminum, Carbon Steel, Stainless Steel
UB-Type	740 psi @ 100°F (5,102 kPa @ 38°C)	Chemraz	Housing: Carbon Steel; Float: Stainless Steel; Internal Parts: Carbon Steel, Stainless Steel

² Maximum working pressures are for temperatures of -20°F to 100°F (-28°C to 38°C).

Dimensions and Weights

Inches (mm) and Pounds/kg

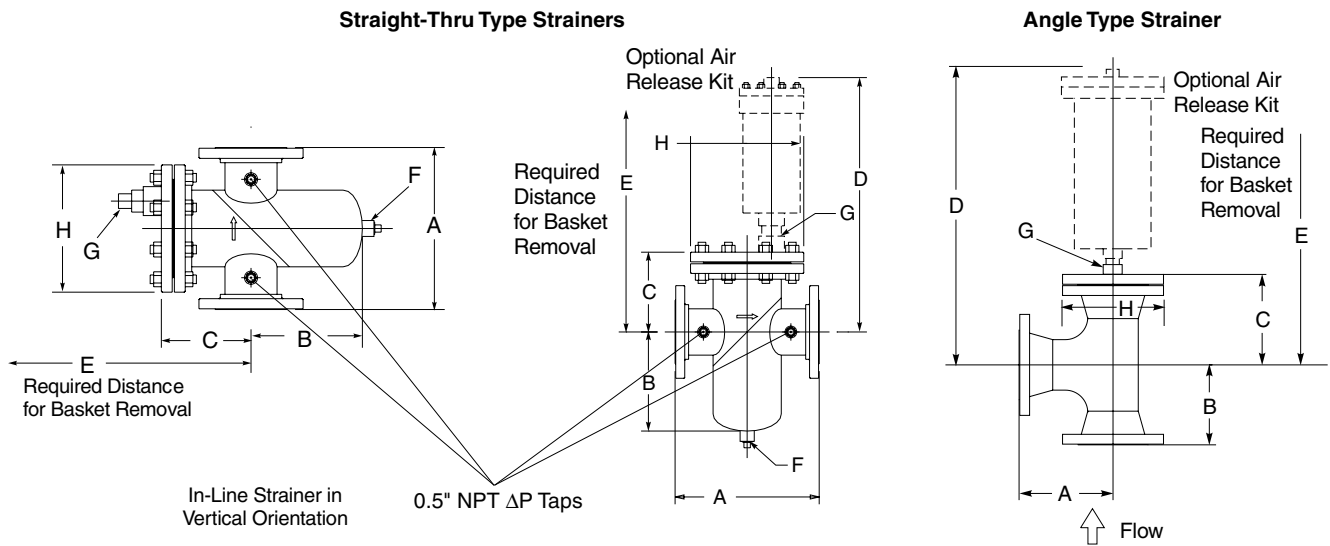

Model	Inlet-Outlet Flange Size & Class	Dimensions								Weight	
		A	B	C	D	E	Drain F (NPT)	Vent G (NPT)	H	Lb	Kg
Straight-Thru Type Strainers											
S2-1-ST	2" 150 RF	10.0 (254)	8.9 (226)	6.0 (152)	23.0 (584)	20.9 (531)	0.75	1.50	9.0 (229)	60	27.2
S2-3-ST	2" 300 RF	13.6 (345)	8.9 (226)	6.0 (152)	23.0 (584)	20.9 (531)	0.75	1.50	10.0 (254)	85	38.6
S3-1-ST	3" 150 RF	13.5 (343)	11.6 (295)	7.5 (190)	24.5 (622)	26.6 (676)	0.75	1.50	11.0 (279)	85	38.6
S3-3-ST	3" 300 RF	20.9 (531)	11.0 (279)	7.6 (194)	24.6 (625)	26.2 (665)	0.75	1.50	12.5 (318)	120	54.4
S4-1-ST	4" 150 RF	14.0 (356)	10.6 (269)	7.3 (184)	24.3 (617)	25.2 (640)	0.75	1.50	11.0 (279)	100	45.4
S4-3-ST	4" 300 RF	18.4 (467)	11.3 (287)	7.6 (194)	24.6 (625)	26.5 (673)	0.75	1.50	12.5 (318)	140	63.5
S4-1-HC	4" 150 RF	22.6 (574)	15.9 (406)	11.0 (279)	28.0 (711)	37.9 (963)	1.25	1.50	16.0 (406)	250	113.4
S6-1-ST	6" 150 RF	23.4 (594)	15.9 (406)	11.0 (279)	28.0 (711)	37.9 (963)	1.25	1.50	16.0 (406)	275	124.7
S6-3-ST	6" 300 RF	29.6 (752)	16.8 (427)	16.0 (406)	33.0 (838)	48.8 (1240)	1.25	1.50	17.5 (444)	470	213.2
S8-1-ST	8" 150 RF	27.1 (688)	23.3 (592)	14.0 (356)	31.0 (787)	51.3 (1303)	1.25	1.50	19.0 (483)	430	195.0
S8-3-ST	8" 300 RF	32.8 (833)	21.5 (546)	15.3 (389)	32.3 (821)	52.1 (1323)	1.25	1.50	20.5 (521)	700	317.5
Angle Type Strainers											
A4-1-ST	4" 150 RF	7.1 (180)	7.1 (180)	8.1 (206)	24.1 (612)	18.4 (467)	N/A	1.50	9.0 (229)	79	36
A6-1-ST	6" 150 RF	9.1 (231)	9.1 (231)	10.1 (257)	26.1 (663)	23.7 (602)	N/A	1.50	11.0 (279)	140	64

Note: Dimensions – Inches to the nearest tenth (millimeters to the nearest whole mm), each independently dimensioned from respective engineering drawings. Add 47.0 Lb (21.3 Kg) if Air Release Kit is used.

Modeling

Example: **S2** — **1** — **ST** — **N** — **40** — **00** — **0**

Type/Flange Size

Straight-Thru Type

S2 - 2" **S6** - 6"

S3 - 3" **S8** - 8"

S4 - 4"

Angle Type

A4 - 4"

A6 - 6"

ANSI Flange Class/Max. Working Pressure @ 100° F (38° C)

1 - Class 150 RF / 285 psi

3 - Class 300 RF / 740 psi

A - PN 10

B - PN 16

Body Style

ST - Standard **HC** - High Capacity (4" only)

Special Requirements

N - None

C - CRN

F - FIC 3

P - PWHT (Post Weld Heat Treat)

1 - CRN + FIC 3

2 - FIC3 and Penetrant Testing

3 - FIC3, 100% X-Ray, SPL Hydro

4 - Special Paint

Differential Pressure Gauge/Switch

0 - Pressure Taps Only (Standard)

G - Differential Pressure Gauge

S - Differential Pressure Gauge and Switch

Vent / Air Release

00 - Plugged NPT Vent Port (Standard)

R1 - RB Head w/ Buna-N Seals (300 psig)

R2 - RB Head w/ Viton Seals (300 psig)

U1 - UB Head w/ Viton Seals (720 psig)

U2 - UB Head w/ Chemraz Seals (720 psig)

U3 - UB Head w/ Viton Seals (300 psig)

U4 - UB Head w/ Chemraz Seals (300 psig)

Basket

40 - Basket with 40 Mesh Liner* (Standard)

10 - Basket with 10 Mesh Liner*

20 - Basket with 20 Mesh Liner*

60 - Basket with 60 Mesh Liner*

80 - Basket with 80 Mesh Liner*

PP - 304 SS Perforated Plate - No Liner

S - Special

* Permanent 304 SS Liner

Revisions included in SS03039 Issue/Rev. 0.8 (5/13):

Page 4: Modeling updated under Special Requirements: 2 - FIC3 and Penetrant Testing, 3 - FIC3, 100% X-Ray, SPL Hydro, and 4 - Special Paint.

The specifications contained herein are subject to change without notice and any user of said specifications should verify from the manufacturer that the specifications are currently in effect. Otherwise, the manufacturer assumes no responsibility for the use of specifications which may have been changed and are no longer in effect.

Contact information is subject to change. For the most current contact information, visit our website at www.fmctechnologies.com/measurementsolutions and click on the "Contact Us" link in the left-hand column.

Headquarters:

500 North Sam Houston Parkway West, Suite 100, Houston, TX 77067 USA, Phone: +1 (281) 260 2190, Fax: +1 (281) 260 2191

Measurement Products and Equipment:

Erie, PA USA +1 (814) 898 5000

Ellerbek, Germany +49 (4101) 3040

Barcelona, Spain +34 (93) 201 0989

Beijing, China +86 (10) 6500 2251

Burnham, England +44 (1628) 603205

Dubai, United Arab Emirates +971 (4) 883 0303

Los Angeles, CA USA +1 (310) 328 1236

Melbourne, Australia +61 (3) 9807 2818

Moscow, Russia +7 (495) 5648705

Singapore +65 6861 3011

Integrated Measurement Systems:

Corpus Christi, TX USA +1 (361) 289 3400

Kongsberg, Norway +47 (32) 286700

Dubai, United Arab Emirates +971 (4) 883 0303

Visit our website at www.fmctechnologies.com/measurementsolutions